

SMARTCUBE GF27 THERMOELECTRIC MODEL SPECIFICATIONS (Non-Automated)

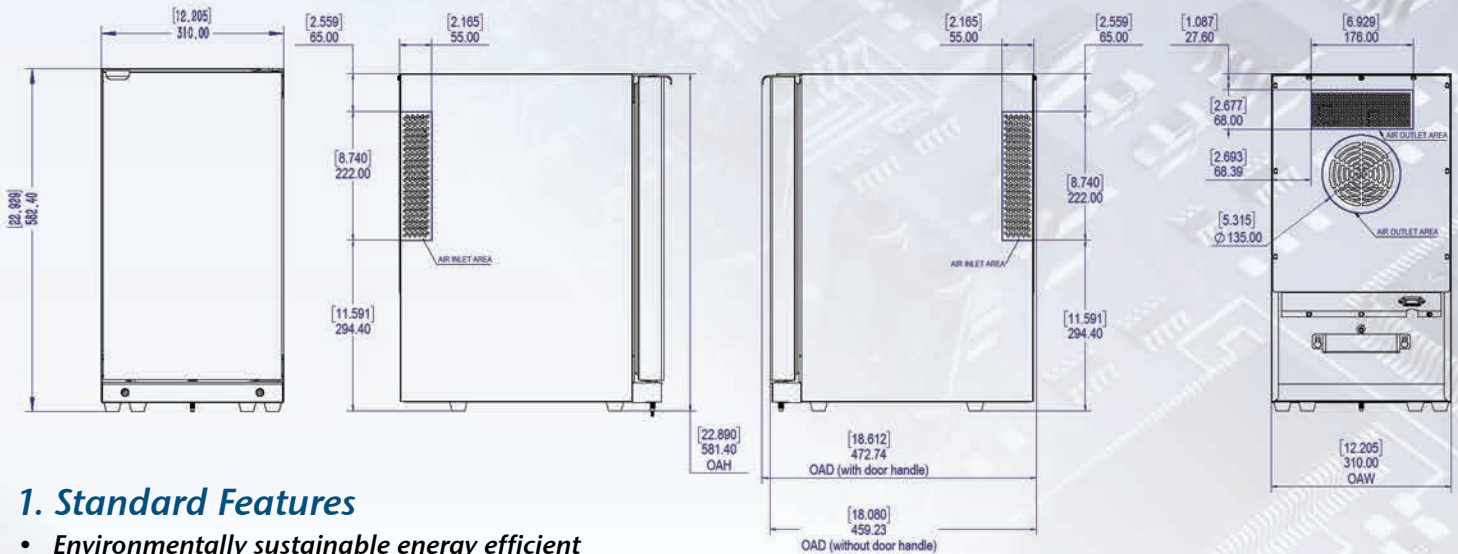



1. Standard Features

- Environmentally sustainable energy efficient thermoelectric cooling system
- Extremely quiet operation
- Removable shelving for easy cleaning
- Cyclopentane thermal foaming insulation (reduces ozone depletion)
- Adjustable thermostat
- Reversible door hinging
- Magnetically sealed doors
- Internal LED lighting
- Automatic defrost
- ADA compliant

Full Glass Door Options

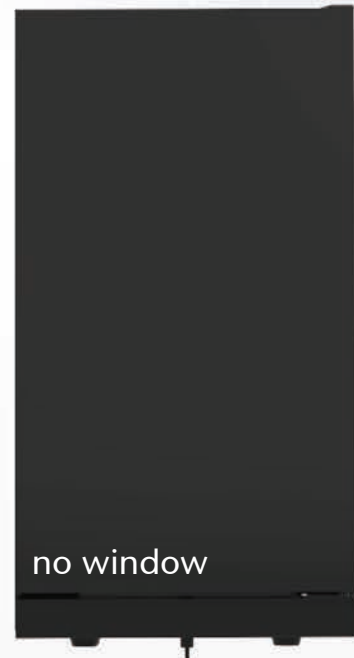

2. Technical Specifications

	GF27T Thermoelectric
Part Number	GF27T
Cooling Type	Peltier Thermoelectric Superconductor 5 Heat Pipe
Capacity (liters / cubic feet)	27 / 0.95
Dimensions HxWxD (inches) HxWxD (mm)	22.92 x 12.2 x 18.55* 582.4 x 310 x 471.1*
Door Option	Full Glass Front: No Window
Watts (W)	60W
Voltage (V)	110V / 60Hz 220V / 50Hz
Amps	0.5-0.9
Energy Consumption (kWh/24h)**	0.43 kWh/24h & 0.4 kWh/24h**
Net Weight (lbs / kgs)	27.12lbs / 12.3 kgs
Noise Level (dB)	40 dB
Certification	CSA/CE/FCC/ETL/WEEE/RoHS ISO 9001 and ISO 14001 certified

* Measured to door handle

**Average energy consumption per 24 hours, at 25°C (77°F) ambient temperature and 7°C (44.6°F) cooling temperature, in compliance with EN ISO 7371

6. Ventilation – Basic Principles

Ventilation occurs by convection, which is the tendency of hot air to rise and colder air to sink. See recommendations in 6.1 through 6.4 on how to achieve proper ventilation.

Note: Proper ventilation and installation are required in order to not void SmartCube warranty.

6.1 Front Air Intake Ventilation (Toe Kick)

The inlet vent(s) must have a minimum open area of 29.98in² (19.31m²) to comply with specifications. This is based on a typical guest room environment of 77° F (25° C) with a relative humidity of no more than 65%. The inlet vent can be provided in any of the following configurations:

- i. A cut-out in the toe kick
- ii. A series of slots in the toe kick
- iii. A grill in the toe kick
- iv. An arched opening in the toe kick

Note: For optimal ventilation a door should not be installed in front of SmartCube.

6.2 Case Good Base Ventilation (Bottom Cut-Out)

The cabinet bottom is to be cut away directly behind and below the cooling unit. The shelf cutout must have a minimum open area of 45.91in² (29.62m²). The easiest way to accomplish the required ventilation is to cut away across the complete width and extend the cut out back to the rear of the case good.

6.3 Case Good Side Ventilation (Side Vent)

Side inlets should be cut to a minimum open area of 54.25in²(35m²). It is recommended to have two side inlets but at a minimum of one inlet would be acceptable alternative.

6.4 Exhaust Ventilation (Grill or Back Vent)

1. Back Exhaust ventilation (see Fig 6.1) – Cut out in the back allowing trapped heat to escape.
2. Top Exhaust Ventilation (see Fig 6.4) – Grill/Vent cut out on top for trapped heat to escape

Note: Ventilation from back requires a minimum 1.5in (38mm) air gap behind the case good for exhaust flow.

Front View Fig 6.1 & Back Ventilation Fig 6.4

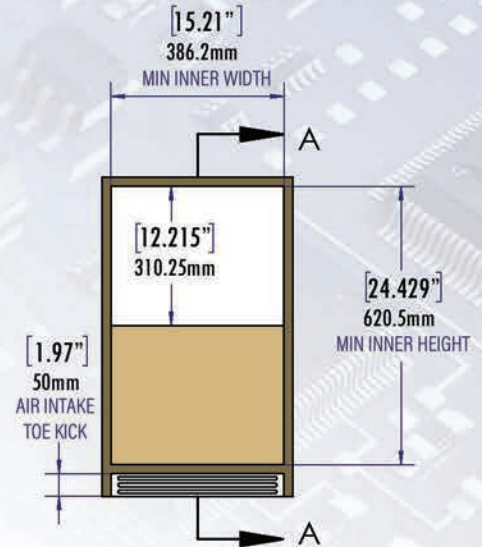

Bottom View Fig 6.2

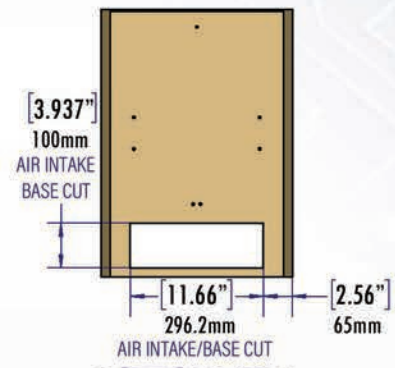

Side Section View Fig 6.3

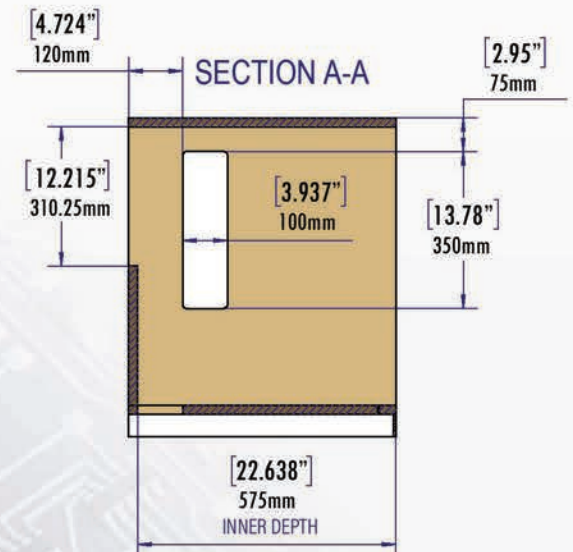

6.4 Exhaust Ventilation Continued

Exhaust ventilation is required in the case good to prevent warm air from being trapped in the top section causing the SmartCube to overheat. The exhaust vent(s) must have a minimum open area of 52.97in² (34.15m²) to comply with specifications (see Fig. 6.1). The exhaust vent(s) can be provided in any of the following configurations:

- i. A series of slots or a grill in the top
- ii. A series of slots or a grill in the back at the top
- iii. If the design will not permit the use of slots or a grill, the unit should be spaced 1.5" (38.1mm) from the wall to allow proper exhaust. Use spacers or stoppers to prevent the case good from being pushed up against the wall. In this configuration, the back of the case good must be cut away see Fig 6.1. The underside of the shelf above the SmartCube must be flat so that there are no obstruction to the airflow.

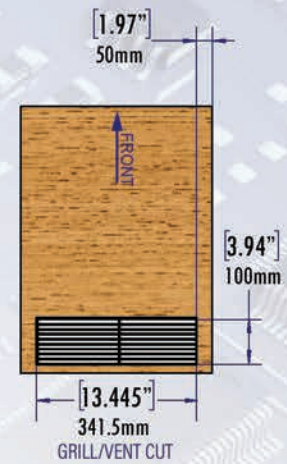

The exhaust vent must exit into free space in the guest room. It must not vent into an enclosed space such as a closet, case good or ceiling void, as the heat will be trapped. The SmartCube must not be placed up against a heating radiator, window curtains or in direct sunlight. Ventilation grills or slots must not be covered. Please contact your Minibar Systems representative for review and certification of your case good design and drawings to ensure your design meets the SmartCube and SmartCube Case Good Specifications. If these ventilation requirements are not met, the warranty is void. The case good documents can be found on the SmartCube.MinibarSystems.com website or from your Minibar Systems representative.

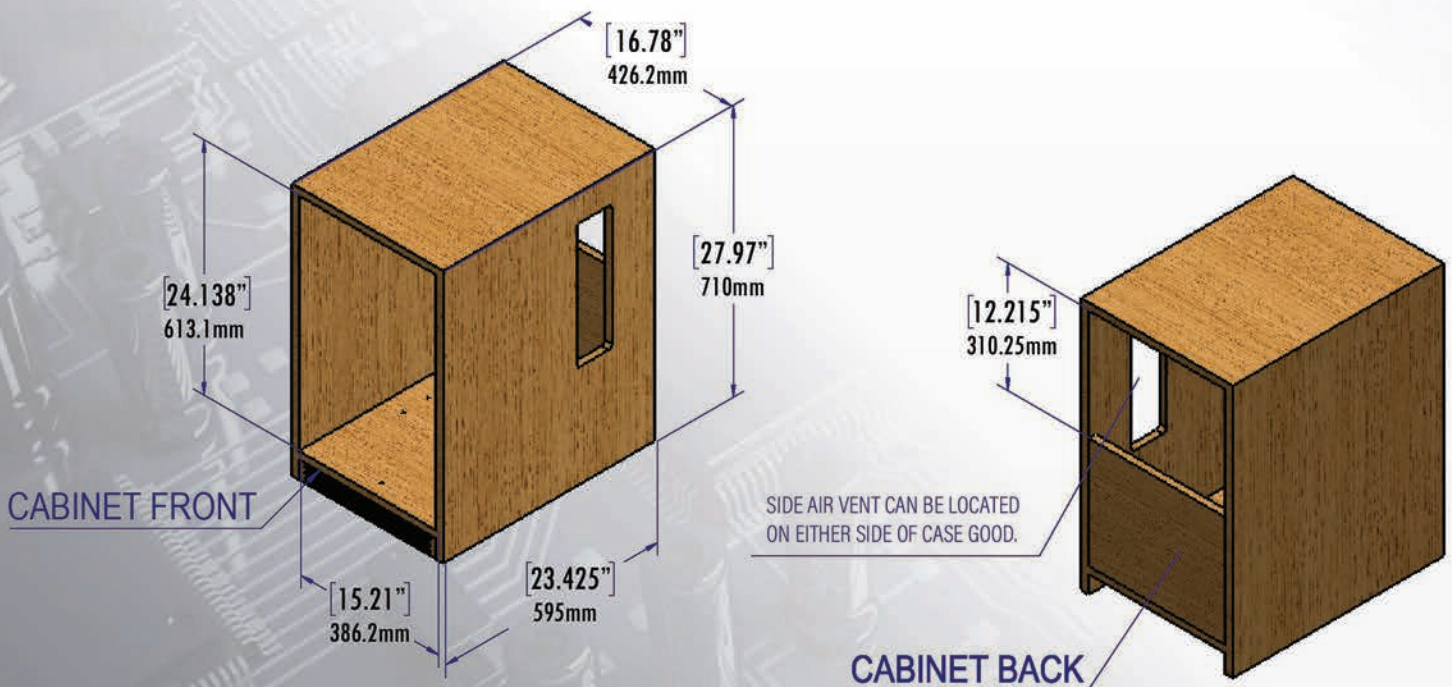

7. Ventilation and Cavity Requirements

Lateral cut-outs should line up with air intakes and air outlets.

Minimum Ventilation	Optimal Ventilation	Optional
<ul style="list-style-type: none"> - Toe Kick - Base Cut-Out - One Lateral Side Cut-Out - Back Cut-Out 	<ul style="list-style-type: none"> - All Minimum Ventilation Requirements - 2nd Lateral Side Cut-Out - No Door 	<ul style="list-style-type: none"> - Counter Top Vent (Only if a back cut-out is not available)

7.1 Space Required Between Case Good and Wall

Case good should be installed 1.5" (38mm) from the wall

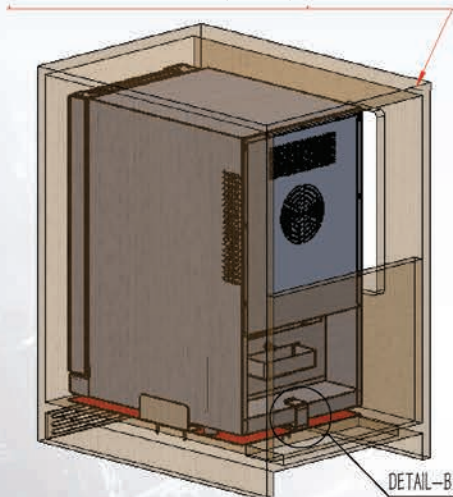

Keep at least 1.5" (38mm) clearance around the minibar and case good

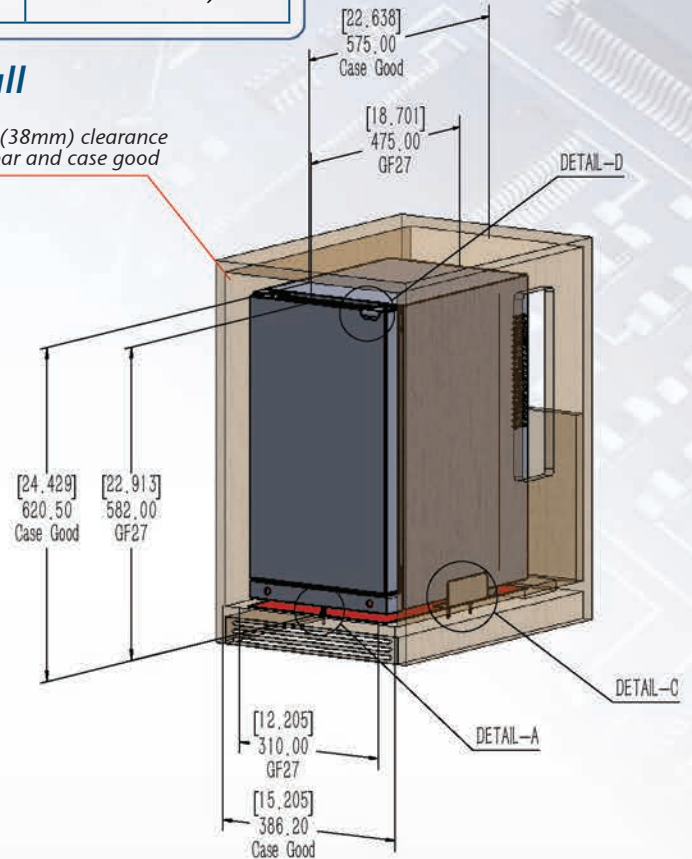

Note: If cut-outs align with air intake/outlets of the SmartCube you can minimize the size of the area surrounding the SmartCube by 1.5" (38mm). If cut-outs do not directly line up then a 1.5" (38mm) air gap is required around the unit.

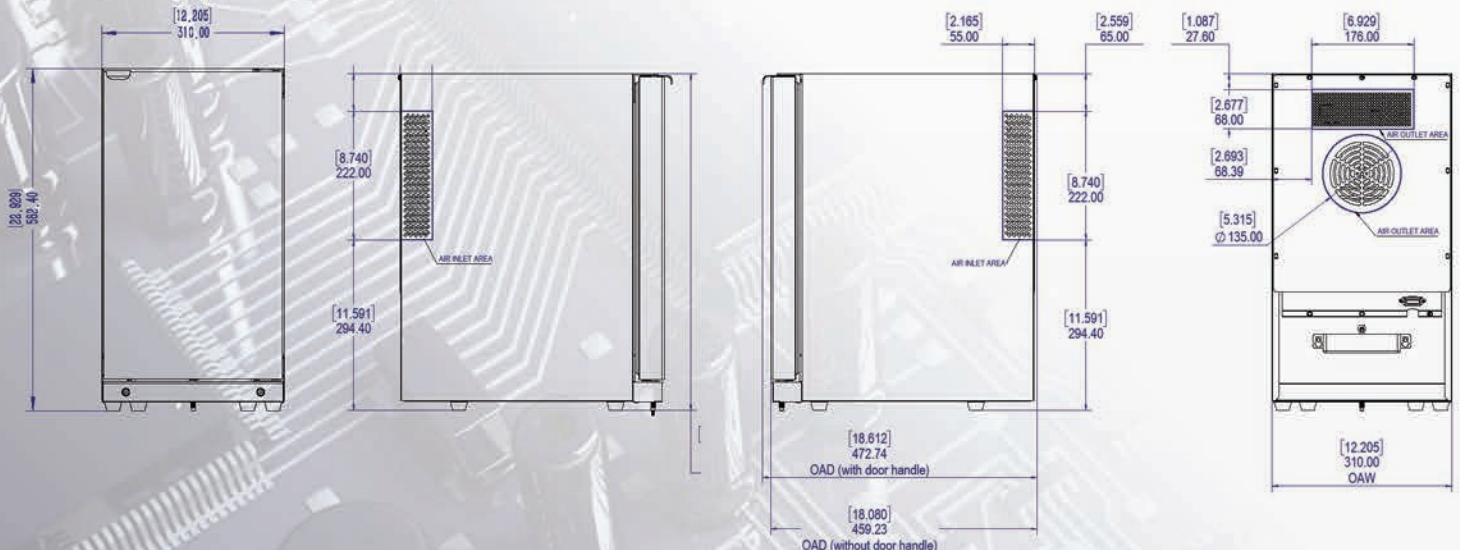

8. Installing Anti-Tilt Bracket and Securing to Case Good

SmartCube should be secured to case good using supplied hardware: 2 side brackets, anti-tilt bracket, and front mounting screw

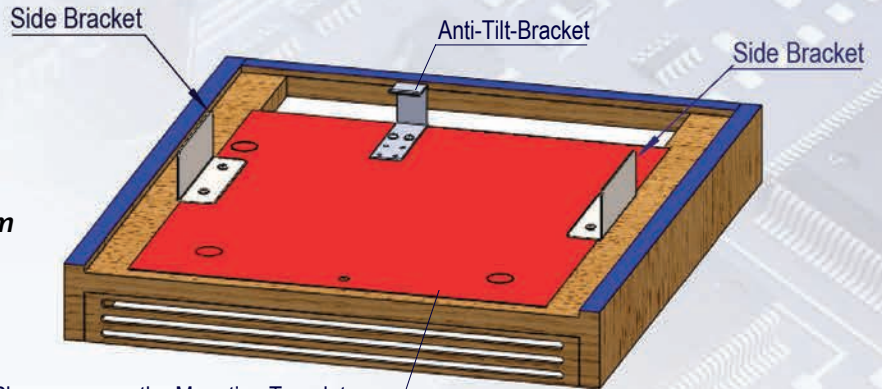

Please remove the Mounting Template, once the brackets are fixed at the locations

8.1 Installing Anti-Tilt Bracket

Anti-tilt bracket should be mounted to bottom of case good using provided hardware and template.

DETAIL B
1 : 2

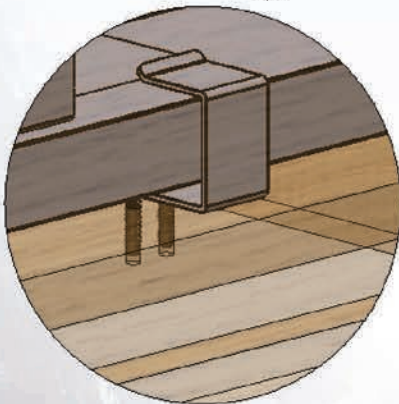

8.2 Mounting Side Bracket

Side brackets should be mounted to case good using provided hardware and template.

DETAIL-D
1 : 2

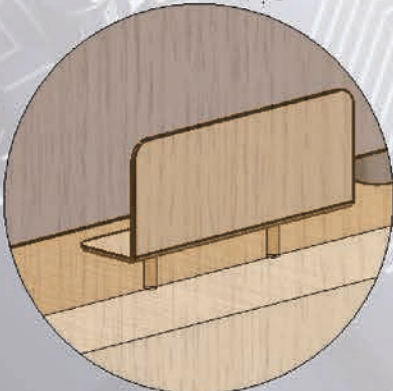

GF-27 Mounting Template

FRONT (FACING TO DOOR)

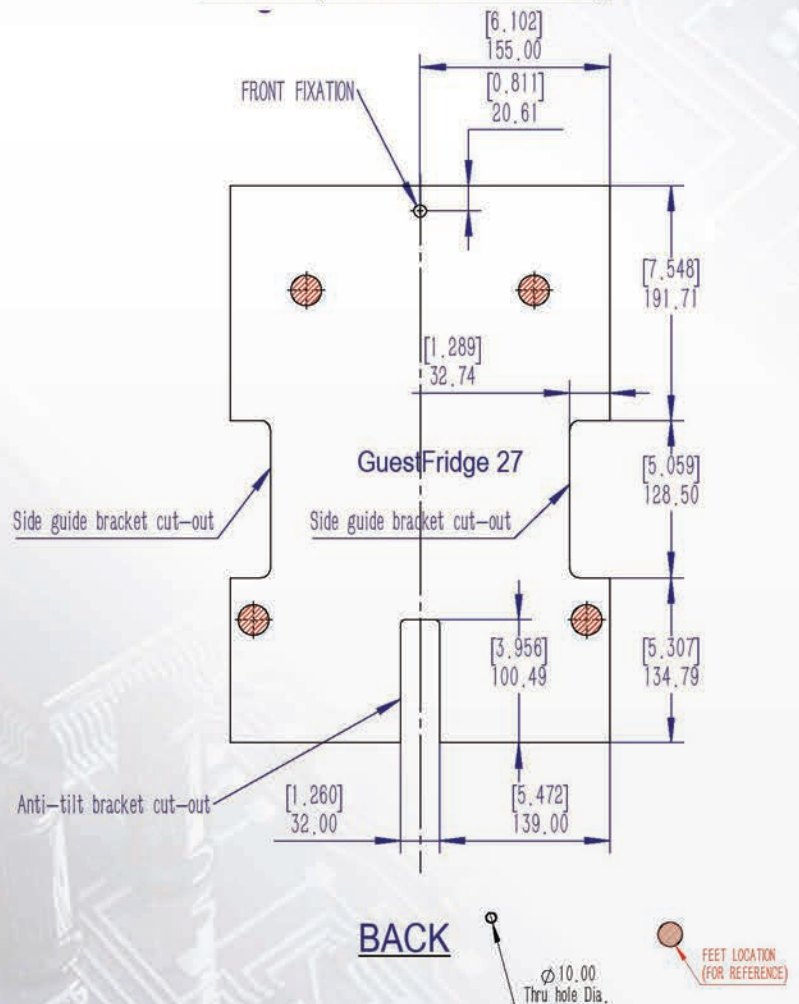

8.3 Installing & Anchoring SmartCube

SmartCube should be secured to case good from front using supplied hardware: front mounting screw

