

SMARTCUBE CLASSIC DRAWER DC40T MODEL SPECIFICATIONS (non-Automated)

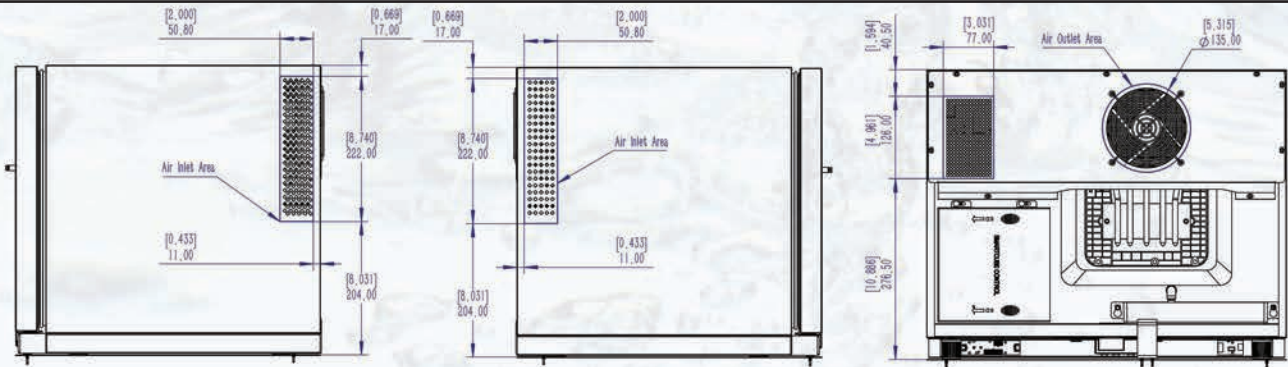



1. Standard Features

- Environmentally sustainable energy efficient thermoelectric cooling system
- Translucent racking on door for high visibility of products
- 30% more energy efficient over previous models
- State-of-the-art insulation properties
- Cyclopentane thermal foaming insulation (reduces ozone depletion)
- ADA-compliant, can open with one hand
- Extremely quiet operation
- Solid metal drawer, not plastic
- Lower drawer is self closing
- All-round magnetic seals to keep the door closed
- Internal automatic LED lighting
- Fully automatic defrost
- Strong metal drawer slides
- Customized front panel to integrate with design
- Low energy consumption

2. Upgradable Design

- Classic Honor Bar -> Door Open -> Fully Automated
- Maximum Flexibility

3. Technical Specifications

Classic Drawer Thermoelectric	
Part Number	DC-40T
Cooling Type	Peltier Thermoelectric Superconductor S Heat Pipe
Capacity (liters / cubic feet)	40 / 1.41
Dimensions HxWxD (inches)* HxWxD (mm)*	17.52 x 21.65 x 20.47* 445 x 550 x 520*
Drawer Option	Drawer
Watts (W)	40W
Voltage (V)	110V / 60Hz 220V / 50Hz
Amps	0.35-0.75
Energy Consumption (kWh/24h)**	0.32 kWh/24h**
Net Weight (lbs / kgs)	49.6lbs / 22.5kgs
Noise Level (dB)	40 dB
Certification	CSA/CE/FCC/ETL/WEEE/RoHS ISO 9001 and ISO 14001 certified

Door Options

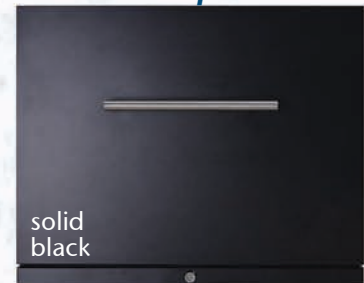

Top Drawer



Self Closing Drawer Sliders



Upper & Lower Drawer Layout



*Depth measured with handle. remove 0.91 inches (23 mm) to the depth of the Classic Drawer with no handle

**Average energy consumption per 24 hours, at 25°C (77°F) ambient temperature and 4°C (39.2°F) cooling temperature, in compliance with EN ISO 7371

4. Ventilation – Basic Principles

Ventilation occurs by convection, which is the tendency of hot air to rise and colder air to sink. See recommendations in 4.1 through 4.4 on how to achieve proper ventilation.

Note: Proper ventilation and installation are required in order to not void SmartCube warranty.

4.1 Front Air Intake Ventilation (Toe Kick)

The inlet vent(s) must have a minimum open area of 43.9in² (28.31m²) to comply with specifications. This is based on a typical guest room environment of 77° F (25° C) with a relative humidity of no more than 65%. The inlet vent can be provided in any of the following configurations:

- i. A cut-out in the toe kick
- ii. A series of slots in the toe kick
- iii. A grill in the toe kick
- iv. An arched opening in the toe kick

Note: For optimal ventilation a door should not be installed in front of SmartCube Classic..

4.2 Case Good Base Ventilation (Bottom Cut-Out)

The cabinet bottom is to be cut away directly behind and below the cooling unit. The shelf cut-out must have a minimum open area of 73.81in² (47.62m²). The easiest way to accomplish the required ventilation is to cut away across the complete width and extend the cut out back to the rear of the case good.

4.3 Case Good Side Ventilation (Side Vent)

Side inlets should be cut to a minimum open area of 54.25in²(35m²). It is recommended to have two side inlets but at a minimum of one inlet would be acceptable alternative.

4.4 Exhaust Ventilation (Grill or Back Vent)

1. Back Exhaust ventilation (see Fig 6.1) – Cut out in the back allowing trapped heat to escape.
2. Top Exhaust Ventilation (see Fig 6.4) – Grill/Vent cut out on top for trapped heat to escape

Note: Ventilation from back requires a minimum 1.5in (38mm) air gap behind the case good for exhaust flow.

Front View Fig 6.1 & Back Ventilation Fig 6.4

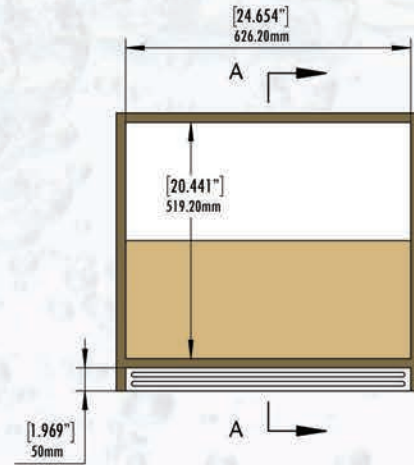

Bottom View Fig 6.2

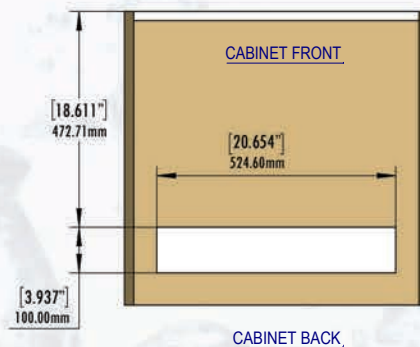

Side Section View Fig 6.3

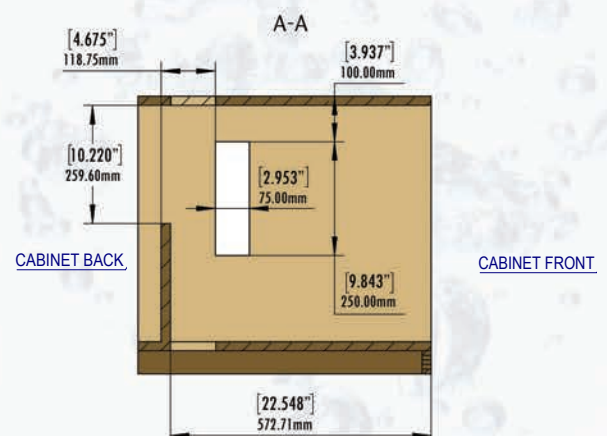

4.4 Exhaust Ventilation Continued

Exhaust ventilation is required in the case good to prevent warm air from being trapped in the top section causing the SmartCube Classic to overheat. The exhaust vent(s) must have a minimum open area of 269in² (173.57m²) to comply with specifications (see Fig. 6.1). The exhaust vent(s) can be provided in any of the following configurations:

- i. A series of slots or a grill in the top
- ii. A series of slots or a grill in the back at the top
- iii. If the design will not permit the use of slots or a grill, the unit should be spaced 1.5" (38.1mm) from the wall to allow proper exhaust. Use spacers or stoppers to prevent the case good from being pushed up against the wall. In this configuration, the back of the case good must be cut away see Fig 6.1. The underside of the shelf above the SmartCube Classic must be flat so that there are no obstruction to the airflow.

Top View Fig 4.4
(Optional Ventilation)

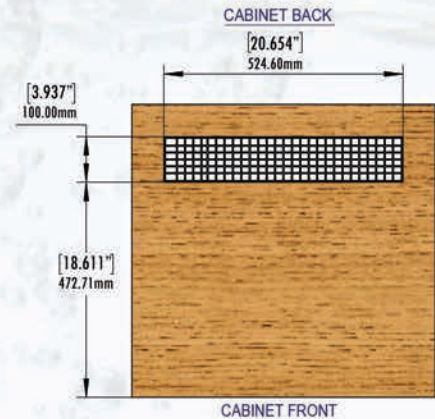

The exhaust vent must exit into free space in the guest room. It must not vent into an enclosed space such as a closet, case good or ceiling void, as the heat will be trapped. The SmartCube Classic must not be placed up against a heating radiator, window curtains or in direct sunlight. Ventilation grills or slots must not be covered. Please contact your Minibar Systems representative for review and certification of your case good design and drawings to ensure your design meets the SmartCube and SmartCube Case Good Specifications. If these ventilation requirements are not met, the warranty is void. The case good documents can be found on the SmartCube.MinibarSystems.com website or from your Minibar Systems representative.



5. Ventilation and Cavity Requirements

Lateral cut-outs should line up with air intakes and air outlets.

Minimum Ventilation	Optimal Ventilation	Optional
<ul style="list-style-type: none"> - Toe Kick - Base Cut-Out - One Lateral Side Cut-Out - Back Cut-Out 	<ul style="list-style-type: none"> - All Minimum Ventilation Requirements - 2nd Lateral Side Cut-Out - No Door 	<ul style="list-style-type: none"> - Counter Top Vent (Only if a back cut-out is not available)

5.1 Space Required Between Case Good and Wall

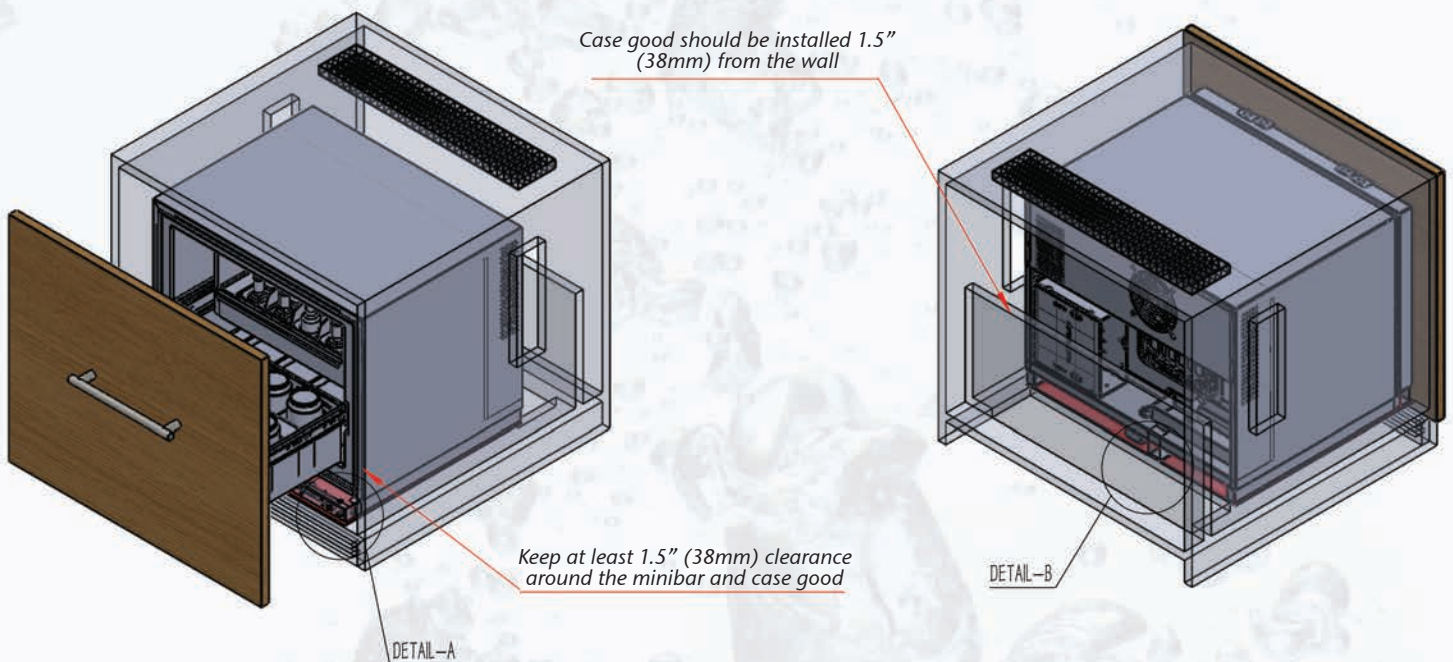

Note: If cut-outs align with air intake/outlets of the SmartCube you can minimize the size of the area surrounding the SmartCube by 1.5" (38mm). If cut-outs do not directly line up then a 1.5" (38mm) air gap is required around the unit.

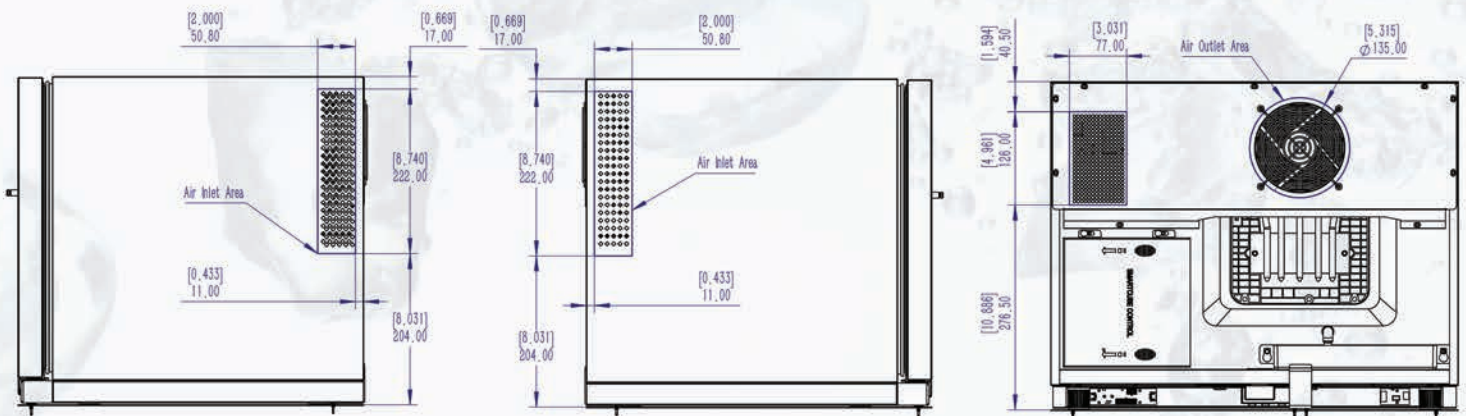

6. Installing & Securing SmartCube Classic to Case Good

The SmartCube Classic should be secured to case good using supplied hardware: 2 side brackets, anti-tilt bracket, and front mounting screw

6.1 Installing Anti-Tilt Bracket

Anti-tilt bracket should be mounted to bottom of case good using provided hardware and template.

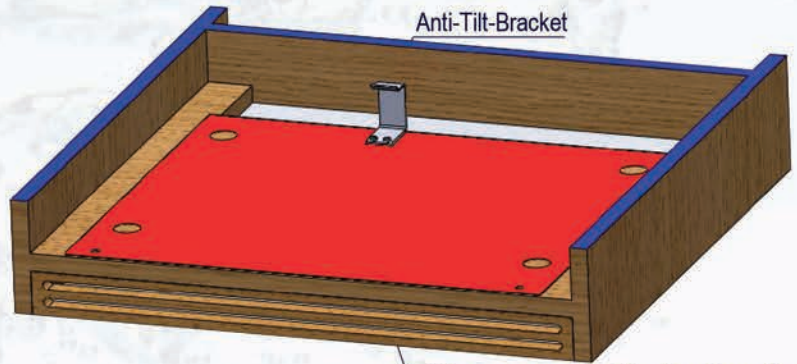

Please remove the Mounting Template, once the brackets are fixed at the locations

DETAIL-B
1 : 2

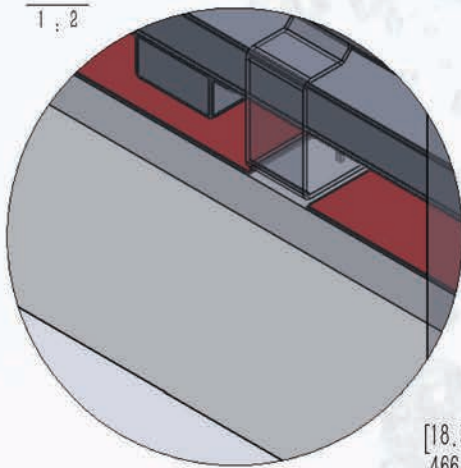

SmartCube Classic 60T Mounting Template FRONT (FACING TO DOOR)

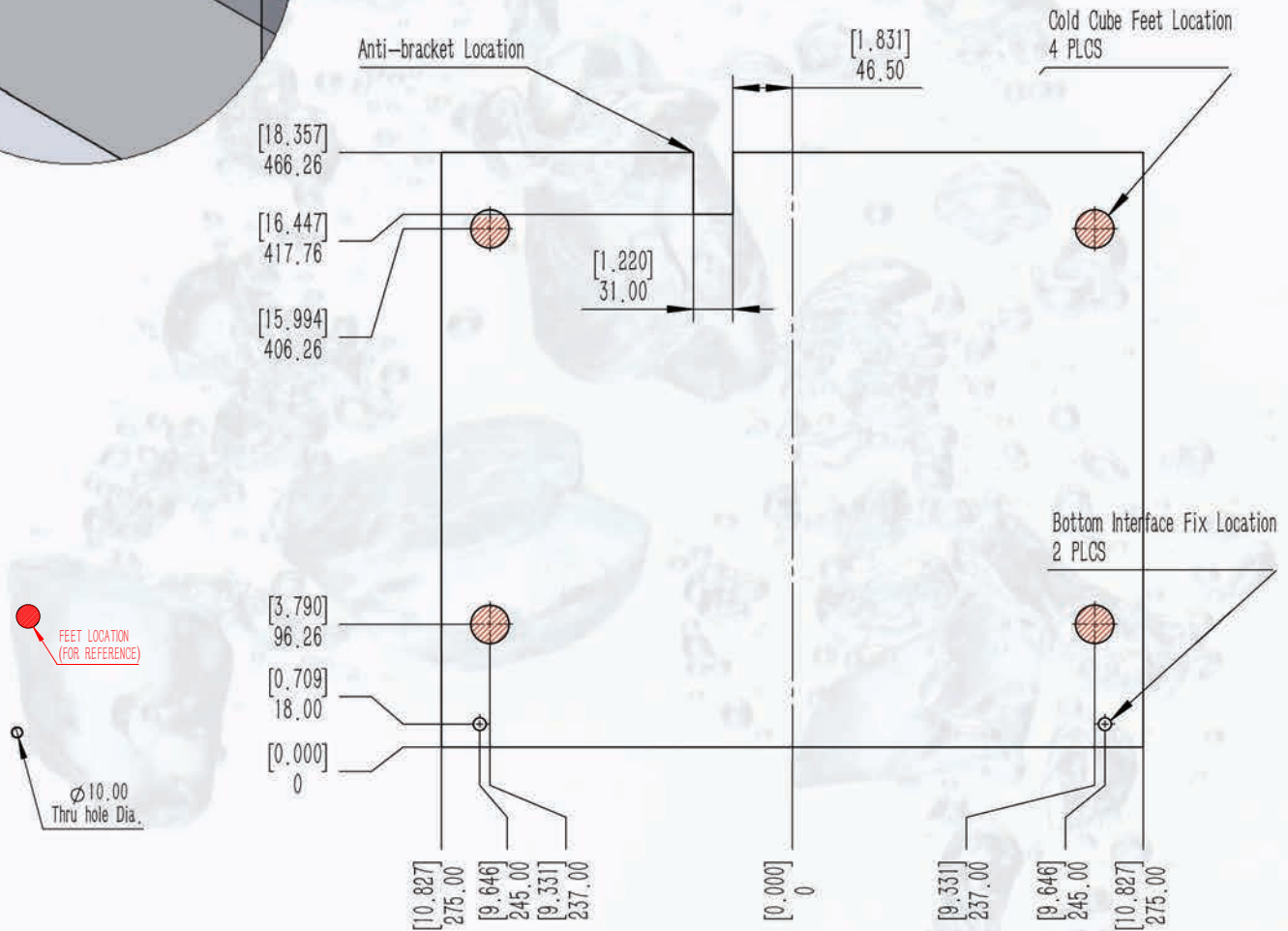

BACK

6.2 Installing & Securing SmartCube Classic to Case Good

SmartCube Classic should be secured to case good from front using supplied hardware: front mounting screw

